

# MOTORISED BRUSH CLEANER

## Effective Cleaning Solution for Chevron, Cleated and Raised-rib Belts

Chevron, cleated and raised-rib belts present a special problem for efficient cleaning. The Motorised Brush Cleaner is an ideal option for cleaning these belts. It also performs well as the second or third cleaner in a system with worn or pitted belts, as the bristles effectively dislodge trapped material.

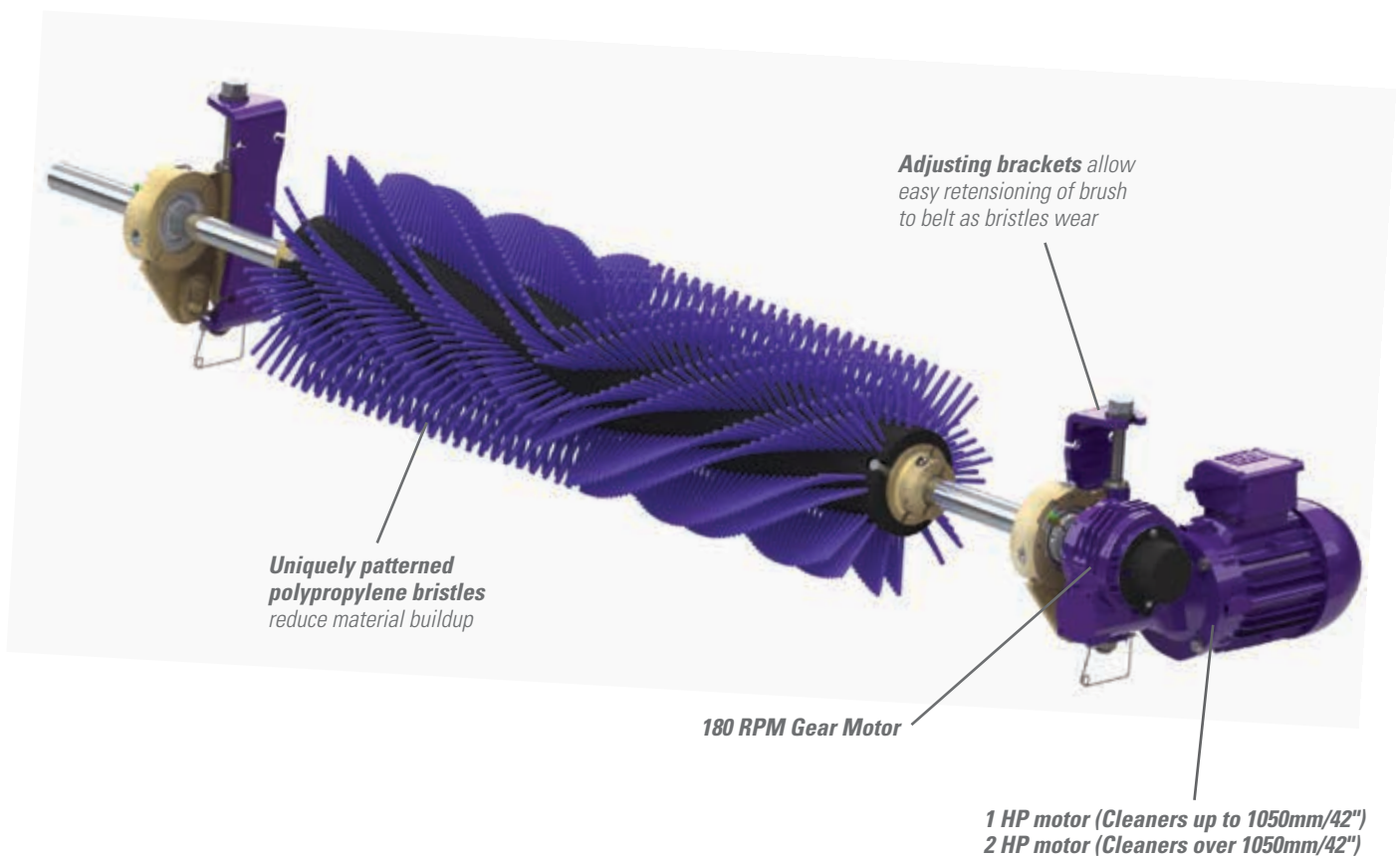

### Features and Benefits

- **Maximum Cleaning.** Spins opposite the belt direction for optimal cleaning.
- **Uniquely patterned bristles.** Aids in reducing material buildup and clogging.
- **Adjustable tensioners.** Allows easy brush-to-belt adjustment as the bristles wear.
- **Works on mechanically spliced or vulcanized belts.**

# MOTORISED BRUSH CLEANER

## Specifications and Guidelines

- **Maximum Belt Speed**  
3.5 M/sec (700 FPM)
- **Temperature Rating**  
-30° C to 82° C (-20°F to 180° F)
- **Overall Brush Diameter**  
305mm (12")
- **Bristle Material**  
Polypropylene
- **Bristle Length**  
83mm (3-1/4")
- **Brush RPM**  
180
- **Shaft Length**  
Belt Width + 915mm (36")
- **Shaft Diameter**  
38mm (1-1/2")
- **Maximum Chevron or Cleat Height**  
13mm (1/2")
- **Motor HP**  
Cleaners 450-1050mm (18-42") - 1 HP  
Cleaners 1200-2100mm (48-84") - 2 HP
- **Motor Voltage**  
208-230/460 VAC 3 Phase\*  
\* other motors available upon request
- **Available for Belt Widths**  
450 to 2100mm (18" to 84")
- **Horizontal Clearance Required**  
305mm (12")
- **Vertical Clearance Required**  
305mm (12")

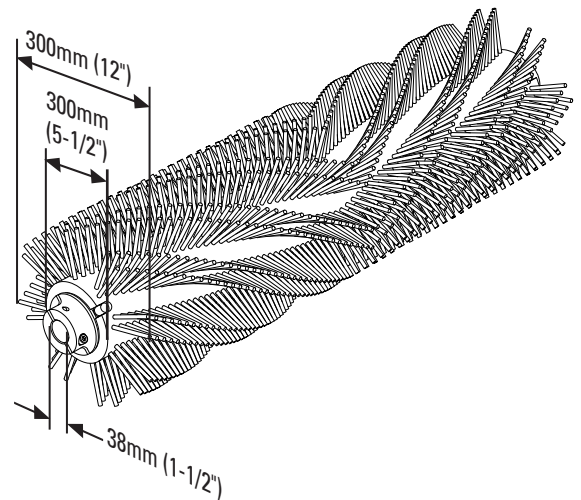
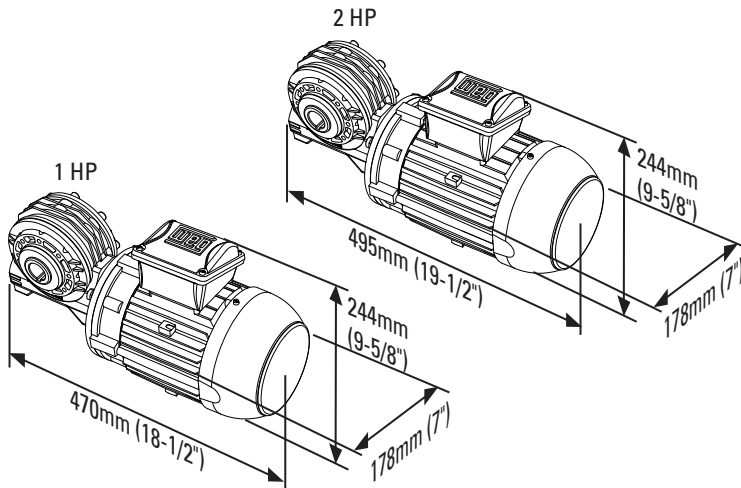

## Ordering Information

Motorised Brush Cleaner				Replacement Brushes			
Belt Width		Brush Coverage		Ordering Number	Item Code	Ordering Number	Item Code
mm	in.	mm	in.				
450	18	450	18	MBC-18	79494	MBRD-18	79514
600	24	600	24	MBC-24	79495	MBRD-24	79515
750	30	750	30	MBC-30	79496	MBRD-30	79516
900	36	900	36	MBC-36	79497	MBRD-36	79517
1050	42	1050	42	MBC-42	79498	MBRD-42	79518
1200	48	1200	48	MBC-48	79499	MBRD-48	79519
1350	54	1350	54	MBC-54	79500	MBRD-54	79520
1500	60	1500	60	MBC-60	79501	MBRD-60	79521
1800	72	1800	72	MBC-72	79502	MBRD-72	79522
2100	84	2100	84	MBC-84	79503	MBRD-84	79523

Lead time: 1 working day

Authorized Distributor:

236 Albert Amon Rd • Meadowdale Ext. 7 • Germiston 1614 • South Africa  
Tel: +27-11-608-4180 • Fax: +27-11-454-5821 • E-mail: flexco@flexco.co.za

Visit [www.flexco.com](http://www.flexco.com) for other Flexco locations and products.

©2015 Flexible Steel Lacing Company. 07/15. For reorder: X3962

